

PRODUCT INFORMATION

DF150/175

BIG
150/175
BLOCK

FOUR STROKE ELECTRONIC FUEL INJECTION



Way of Life!

DF150/175 PRODUCT INFORMATION

Fresh Ideas, Advanced Technology and Innovative Design Keep Suzuki Ahead of the Competition

Unrivaled expertise, world-class technology, innovative ideas and design... That's an excellent summary of what you can find in Suzuki's line of four-stroke outboards. At Suzuki, our goal has always been to provide boaters with the power to get the most enjoyment from their boating experience. To that end, we have employed outside-the-box thinking, cutting edge technology, and refined designs to develop a line of four-stroke outboard motors unmatched by the competition. In so doing, Suzuki built the first four-stroke outboard with digital electronic fuel injection; created the first four-stroke outboard with a self-adjusting and maintenance-free timing chain; developed the first use of an offset drive shaft with two-stage mixed cam drive; and designed and built the world's first 300 horsepower V6 four-stroke outboards.

Our commitment to new and better ideas has earned us the respect of the industry and acclaim from satisfied customers. As proof, Suzuki has been awarded four NMMA awards for outboard innovation, not to mention the three "Editors Choice" awards from Motorboating Magazine.

Now we are building on this heritage. Our DF150 and DF175 four-stroke outboards are the most powerful four-cylinder outboards we have ever built. These compact and lightweight outboard motors provide the benefits of fuel efficiency and low emissions. More importantly, they expand on the potential of four-stroke power for marine applications by delivering powerful acceleration, quick throttle response and exhilarating top-end speed.



Big Block – High Performance Engine

Suzuki's DF150 and DF175 are based on an inline four-cylinder DOHC powerhead with a 174.9 cu.in. (2,867cm³) displacement—one of the largest in the four-stroke, four-cylinder category. While the added displacement contributes greatly to exceptional acceleration and velocity, it doesn't mean that these engines are comparatively larger and heavier in size. To the contrary, Suzuki's engineers have targeted these big block motors to be one of the lightest four-strokes in their class.

Taking advantage of advances Suzuki engineers have made in four-stroke engine performance, the DF175 utilizes a continuously variable valve timing system much like that found in our DF250, DF250SS and the flagship DF300. Both the DF150 and DF175 share other advanced features including multi-stage induction and a 32-bit onboard computer that monitors and controls engine functions.

These motors not only meet the 2010 EPA* exhaust emission standards, their clean, efficient operation has allowed them to comply with CARB** 3 Star Ultra Low Emission Standards.

* Exhaust emission standards set by the U.S. Environmental Protection Agency.

** Exhaust emission standards set by the California Air Resources Board.

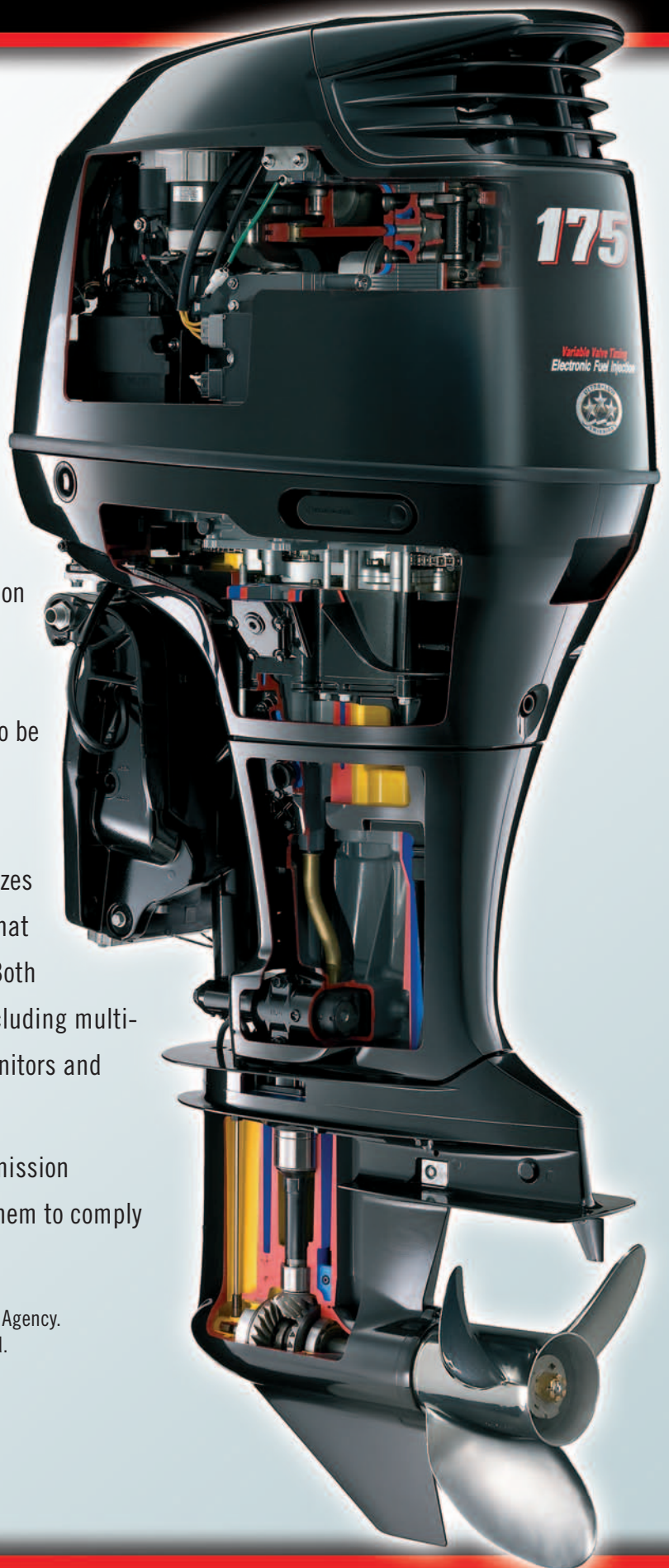

DF150/175 PRODUCT INFORMATION

Advanced Technology for the Performance

Large Displacement

The DF150 and DF175 utilize an inline four-cylinder four-stroke engine with a DOHC four-valve powerhead that produces 150hp and 175hp respectively. At 174.9 cu.in. (2,867cm³) these two outboards offer one of the largest displacement in the four-stroke, four-cylinder category. And thanks to Suzuki's innovative engineering, they are also very light weighing in at 474 lbs. - 20" Transom height / 485 lbs. - 25" Transom height.

VVT (Variable Valve Timing) (DF175)

In designing the DF175, our goal was to expand the potential of the four-stroke engine and create an outboard that delivers high performance along with the benefits of four-stroke technology.

Like the DF250, DF250SS and the flagship D300, the DF175 is designed with an aggressive cam profile and paired with Suzuki's advanced Variable Valve Timing (VVT) to increase the low to mid-range torque outboards need when accelerating. The intake valve actually starts to open before the exhaust valve fully closes, creating a momentary overlap in the timing where both valves are open. Using Variable Valve Timing, this overlap can be increased or decreased by altering intake timing with the camshaft, thereby optimizing camshaft timing for low and mid-range operation.

Multi-Stage Induction (MSI)

The DF150 and DF175 incorporate a multi-stage induction system to enhance engine performance by changing the length of intake manifold pipes according to engine speed. The system utilizes two intake manifold pipes per cylinder, one for operating at low engine speed and another for operating at high. At lower rpm, air enters the combustion chamber through the longer manifold pipe, which is designed to deliver an optimum volume of fresh air into the chamber to improve combustion and boost low-end torque.

As the engine speed surpasses a preset threshold, the valve on the direct intake pipe opens up, letting air enter instantly into the combustion chamber. Shorter and lacking resistance, this pipe gets a greater volume of air into the chamber, increasing the engine's ability to breathe at high rpm, thus improving high speed power output.

Suzuki engineers have equipped these outboards with many other advanced features that contribute to engine performance.

A spherical bore throttle body produces smoother airflow during acceleration. This results in greater engine control and stable operation at low rpm.

Torque

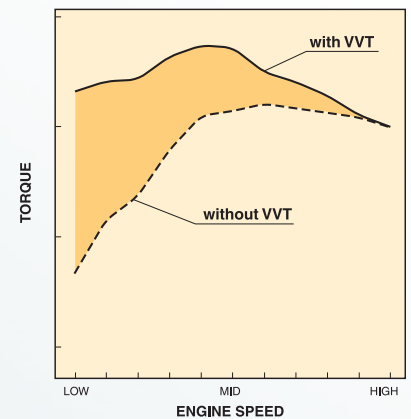

*At the comparison test, Multi-Stage Induction System of the motor was operated.

Air Flow in Multi-Stage Induction Module

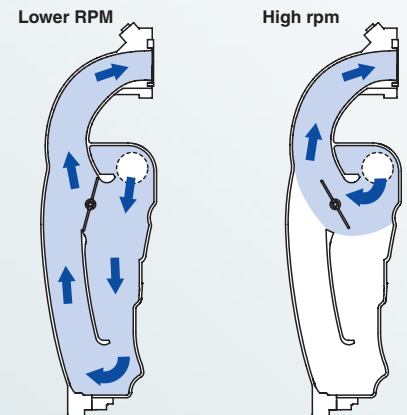

Torque

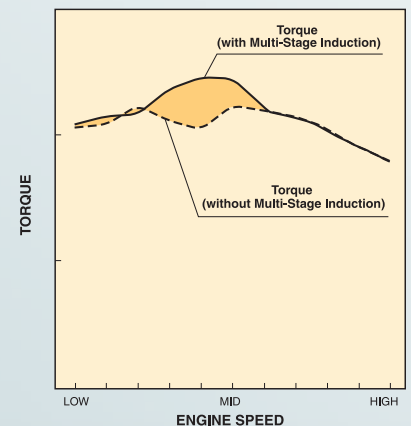

SMOOTH OPERATION

Counter Balancer System

In-line four-cylinder engines operating at high rpms generate a secondary vibration that is directionally in line with the pistons' movement. In order to counter this vibration, Suzuki engineers utilize a secondary balancer system, which produces a horizontal motion against pistons' movement. To produce this horizontal motion, the balancer is divided into left and right sections, each rotating in an opposite direction. Rotating at twice the speed of the crankshaft, the balancers effectively counter these secondary vibrations and produce a smoother operating engine.

Thrust Mount System

In order to reduce vibration and provide stable operation, the DF150 and DF175 use a combination of two different rubber mount types. On both the upper and lower mounts, a combination of soft type and high thrust rubber mounts are utilized. The soft rubber mounts used in this configuration are designed to absorb vibrations produced in the idling through 2,000 rpm operating range. While adding to the compact design and providing an improvement in power and performance, this system also places the high thrust rubber mounts in the best position to provide stable operation under high loads.

Offset Drive Shaft

Suzuki's offset drive shaft has proven successful in reduction of size for the DF70, DF90, DF115, DF140, DF200, DF225, DF250SS and DF300. The DF150 and DF175 benefit from this same design, which positions the crankshaft in front of the drive shaft, simultaneously moving the outboard's

center of gravity forward. While adding to the compactness of the outboard and providing an improvement in power performance, this system also places the engine's axis of inertia, the point where vibrations produced by the engine are at a minimum, up over the upper engine mount thus, greatly reducing vibration.

Quietness

The DF150 and DF175 are powerful outboards, but powerful doesn't mean that they are noisy. Quiet operation has long been an integral feature of the Suzuki four-stroke outboard design goal.

A comparison of engine operating noise levels between the four-stroke DF175 and its two-stroke direct fuel injection (D/I) counterpart is shown in the graph. In this comparison it is clear that the DF175 delivers quieter operation over its entire range than its two-stroke counterpart.

Comparison

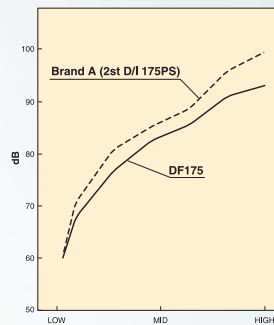

According to Suzuki Internal Running Test

DURABILITY AND RELIABILITY

Suzuki's Anti-Corrosion Finish

Suzuki's anti-corrosion finish is specially formulated to increase the durability of the engine and protect those parts of the aluminum exterior that are constantly exposed to saltwater. Applied directly to the outboard's aluminum alloy, this advanced finish provides maximum bonding of the

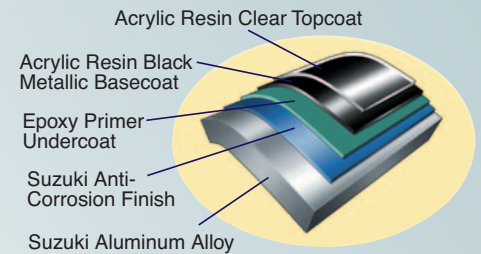

outboard's finish to its aluminum surface. Layered on top is an epoxy primer undercoat, black metallic finish, and clear acrylic fiber finish that together form an effective treatment against corrosion.

Enhanced Air Intake System

Maximizing airflow into the engine is one way to gain maximum power output. The DF150 and DF175 are designed with a large air induction port to increase airflow into the engine. Air is channeled into a large silencer, then through the intake manifold, and finally into the cylinders via a high performance DOHC four-valve-per-cylinder head. The increased airflow results in more low- to mid-range torque and provides a wide powerband that is a must in an outboard engine. The system also includes a water separator which keeps water out of the air intake system.

Offset Drive Shaft

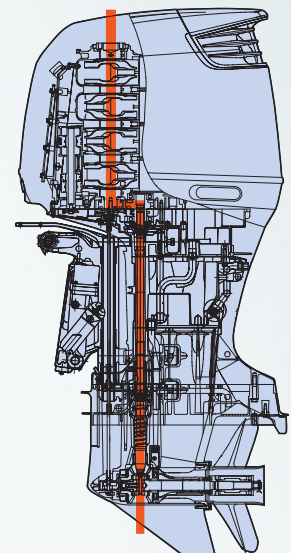

DF150/175 PRODUCT INFORMATION

Advanced Electronics

32-Bit ECM (Engine Control Module)

The ECM (Engine Control Module) allows much more accurate control over the motor's operation, particularly the engine's ignition and fuel delivery systems. The DF150 and DF175 rely on a powerful 32-bit computer in the ECM to monitor and process crucial data, in real time, from a series of sensors placed in critical areas on the engine. This comprehensive network of sensors includes the Manifold Absolute Pressure Sensor, Crankshaft Position Sensor, Intake Air Temperature Sensor, Shift Position Sensor, Throttle Position Sensor, Cylinder Wall Temperature Sensor, Camshaft Position Sensor, and Exhaust Jacket Temperature Sensor. Processing this data in real time, the computer controls the engine's ignition system and provides an ideal fuel supply under all operating conditions.

Multi-Point Sequential Electronic Fuel Injection

As Suzuki was the first outboard motor manufacturer to incorporate multi-point sequential fuel injection in a four-stroke outboard, it is only natural that the DF150 and DF175 would utilize the same. The system injects the optimum amount of fuel at high pressure into each cylinder according to commands from the ECM's 32-bit computer. Along with saving fuel, the system enables the DF150 and DF175 to meet the CARB 3 Star Ultra Low Emission Standards—and pass the EPA's 2010 regulations. Other benefits include quick starts, crisp acceleration, smooth performance, and maximum efficiency.

Multi Point Sequential Electronic Fuel Injection

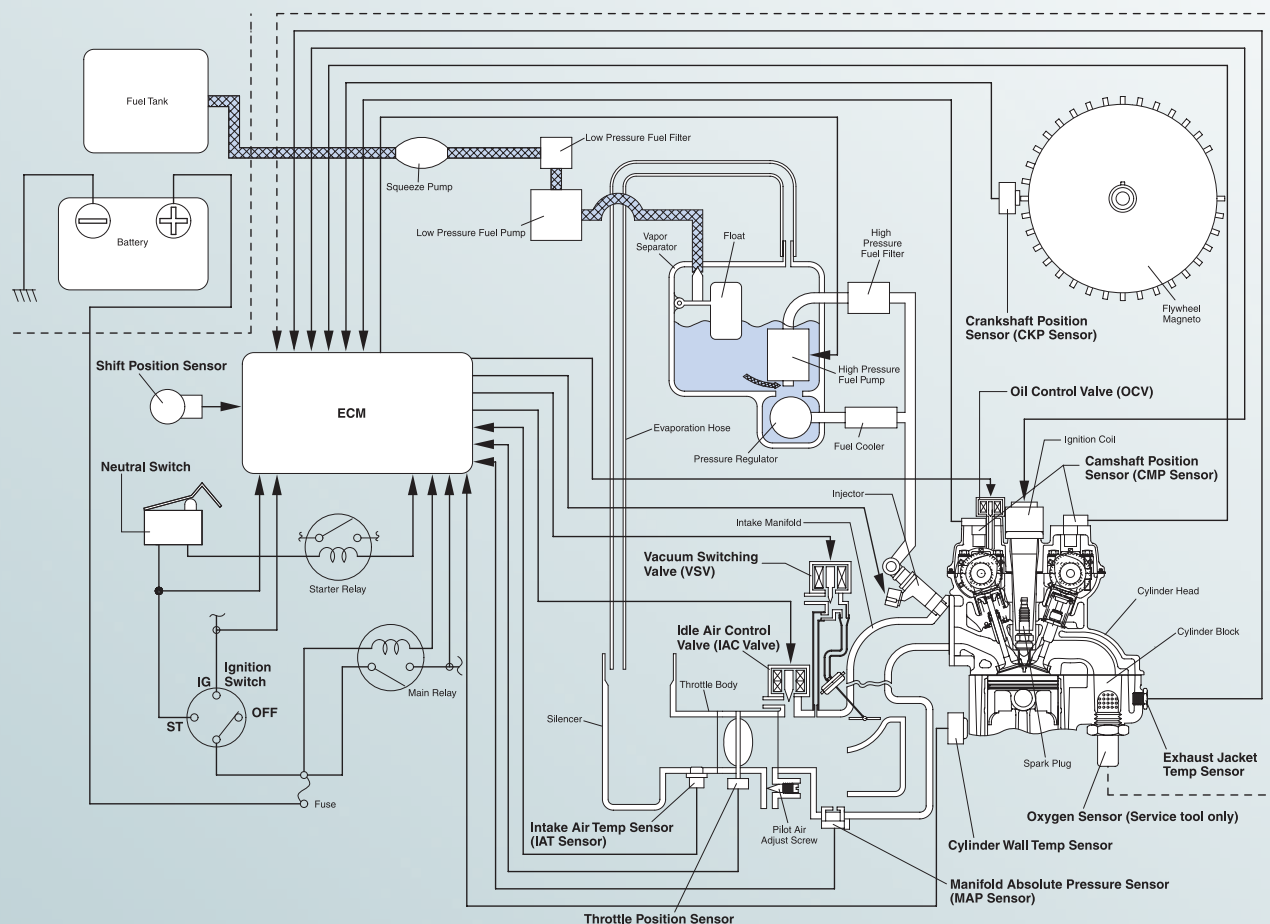

High Output Alternators

The DF150 and DF175 are equipped with alternators that produce a maximum output of 44A (12V) and are capable of producing almost 80% of their total output at a low 1,000 rpm. In most cases, that's enough power to keep an assortment of electronics up and running.

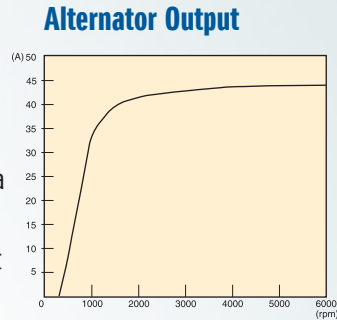

DESIGNED WITH CONVENIENCE IN MIND

Tilt Limit Switch

The motor tilt system incorporates a tilt limit switch that prevents the motor from tilting beyond a predetermined point. The system can be set by the user and can be used to protect both the boat and motor from damage that can occur when tilting the motor.

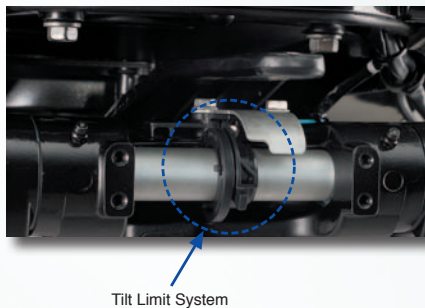

Tilt Limit System

Water-Cooled Voltage Regulator with Isolator

Both outboards incorporate a water-cooled voltage regulator which dissipates heat in the regulator to enhance the engine's durability.

The regulator also includes isolator function in the battery charging system that allows use of two batteries. Electric current is split into two circuits. If the sub battery becomes drained, this system will safeguard the main battery.

Regulator with Dual Circuit Charging System

The DF150/175 features a built in dual circuit charging system that can be adapted* for use with dual-battery configurations. When used in this configuration, the system charges both main and auxiliary

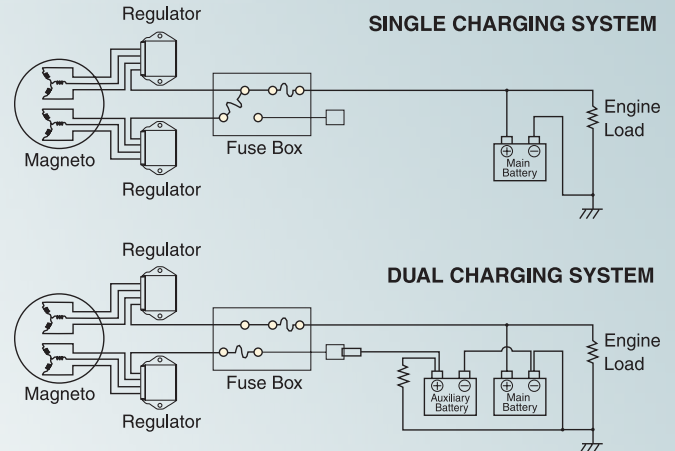

batteries simultaneously on independent circuits. With this design, you can drain down the accessory battery powering your electronics and still have a fully charged main battery for starting the motor.

*Requires purchase of optional wiring harness.

Two Engine Flush Ports

Salt, sand, and dirt can buildup in the engine's cooling system, causing damage over time. The DF150 and DF175 are equipped with two freshwater flush ports to make flushing of the cooling system as convenient as possible. One port located on the port side of the down housing and a second located on the front panel provide easy access and facilitate flushing of the system whether the boat is in or out of the water.



Fuse Box

Fuses protecting outboard's electric system assembled into a single fuse box on the side of the outboard motor. configuration offers convenient and creates a clean exterior.

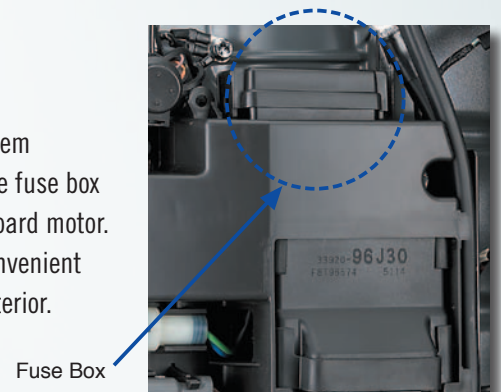

Fuse Box

Suzuki Motor Corporation

A tradition of Innovation

Suzuki history begins with the founding of Suzuki Loom Works by Michio Suzuki in October 1909. Realizing that weaver wanted to produce cloth both vertical and horizontal patterns, he developed an automated loom capable of weaving patterned cloth from space dyed yarn. His commitment to innovative engineering was the start of an uncompromising focus on creating products that meet people's needs and offer new life style possibilities.

While the company has evolved, diversified, and expanded since then, we have always honored our founder's commitment to innovative engineering. His philosophy lives on in the "Way of Life!" brand slogan and our dedication to provide our customers with value packed products that bring satisfaction and meet their needs.

Suzuki Automobiles

Producing over two million cars per year, Suzuki offers an automotive lineup that ranges from Performance Sport Sedan, the Kizashi to an economical compact SX4. Not to mention the "4x4 of the year" Equator pick up truck and the outstanding SUV, the Grand Vitara. Suzuki is one of the leading manufacturers of dependable, fuel efficient vehicles, known globally as being sporty, user friendly, fun to drive and respected for their excellent quality and value.

Suzuki Motorcycles

Suzuki offers a comprehensive lineup of motorcycles that includes super-sport, street, cruisers, dual purpose, scooters, off-road, motocross, and all terrain vehicles. Suzuki motorcycles and ATVs are well known and highly respected for their race-proven cutting edge technologies, functional features, quality, and dependability all tailored to meet the demands of our customers.

Suzuki Outboards

Ranging from the world's first 300 HP four-stroke outboard to the portable DF2.5, Suzuki offers a comprehensive lineup that represents state-of-the-art engine design and technology. The also offer great fuel efficiency and environmentally responsible operation that meets many of the toughest emission standards – world wide. In 2008 Suzuki introduced the first of its new generation four-strokes, the DF90A and DF70A, followed by the DF60A in 2009. 2010 was another big year with the introduction of the DF50A and DF40A and the redesigned DF300A. These outboards deliver clean running economical operation with Suzuki's Lean Burn Technology. At Suzuki, it is our goal to build outboards that are highly efficient, deliver low fuel consumption and high power output while placing less stress on the environment.

Suzuki Motorsports

On the track, Suzuki has captured major championships around the world. The experience, knowledge and expertise gained on the track produces race proven, leading edge technologies that are utilized in every vehicle we make. Suzuki supplies you with the best combination of performance, durability, reliability, efficiency, ease-of-use, and value. It's why Champions Choose Suzuki. So, what are you gonna ride?

To learn more about Suzuki,
visit your local Suzuki dealer or go to
www.suzuki.com



DF150/175 SPECIFICATIONS

MODELS	DF150	DF175
ENGINE TYPE	Four-stroke DOHC 16 valve	
FUEL DELIVERY SYSTEM	Multi Point Sequential Electronic Fuel Injection	
TRANSOM HEIGHT in.	L: 20 X: 25	
STARTING SYSTEM	Electric	
WEIGHT (lbs.) * Dry-weight, not including propeller	L: 474 X: 485	
NO. OF CYLINDERS	In Line 4	
DISPLACEMENT	174.9cu. in. (2,867cc)	
BORE × STROKE in. (mm)	3.81 in. × 3.81 in. (97 × 97)	
MAXIMUM OUTPUT	150 hp	175 hp
FULL THROTTLE OPERATING RANGE rpm	5000-6000	5500-6100
STEERING	Remote	
OIL PAN CAPACITY (U.S. / Imp. qt.)	8.5 qt. (8.0 ltr)	
IGNITION SYSTEM	Solid State Direct Ignition	
ALTERNATOR	12V 44A	
ENGINE MOUNTING	Shear Mount	
TRIM METHOD	Power Trim and Tilt	
GEAR RATIO	2.50 : 1 (Two-stage Reduction Gear)	
GEAR SHIFT	F-N-R	
EXHAUST	Through Prop Hub Exhaust	
DRIVE PROTECTION	Rubber Hub	
PROPELLER SIZE (in.)** OPTIONAL STAINLESS STEEL	3 x 15-1/2 x 17 3 x 15-1/4 x 19 3 x 15 x 21 3 x 14-3/4 x 23 3 x 14-1/2 x 25 3 x 14-1/2 x 27	4 x 14-3/8 x 23 4 x 14-3/8 x 25 4 x 14-3/8 x 27 4 x 14-3/8 x 28 4 x 14-3/8 x 29

DIMENSIONS

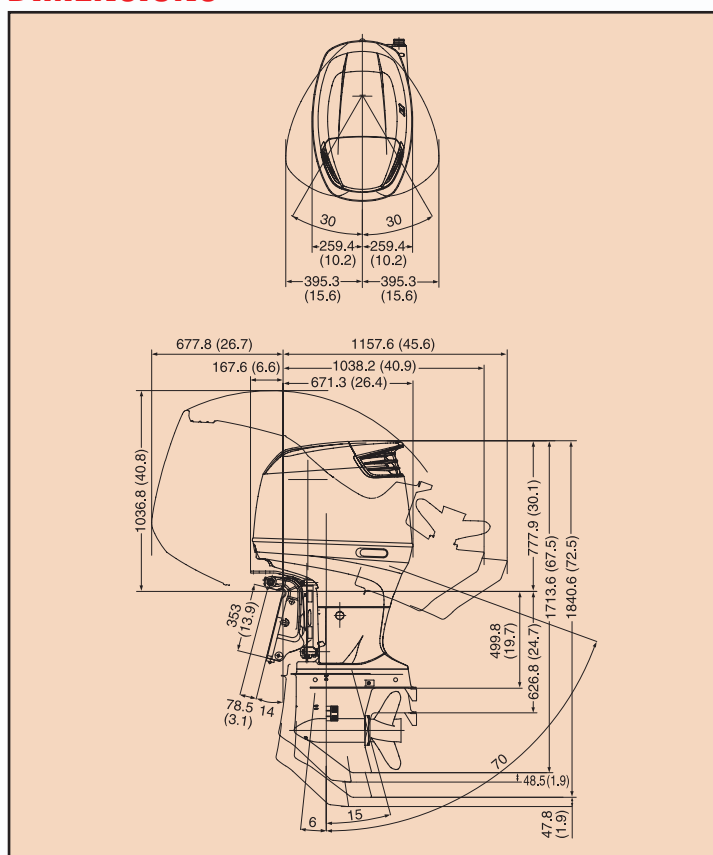

* Counter Rotation Model Available (Transom X only).

** Boats and motors come in a large variety of combinations. See your authorized dealer for correct propeller selection to meet recommended RPM range at W.O.T.

Please read your owner's manual carefully. Remember, boating and alcohol or other drugs don't mix. Always wear a USCG approved life jacket. Please operate your outboard safely and responsibly. Suzuki encourages you to operate your boat safely and with respect for the marine environment.

SUZUKI MOTOR CORPORATION reserves the right to change, without notice or obligation, equipment, specifications, colors, materials and other items to apply to local conditions. Each model may be discontinued without notice. Please inquire at your local dealer for details of any such changes.

Actual body colors may differ slightly from the colors in this brochure.



CARB THREE-STAR LABEL

The three-star label identifies engines that meet the California Air Resources Board's most stringent exhaust emission requirements for outboard motors.



EPA 2010 LABEL

Suzuki's four-stroke technology is compliant with EPA's stringent 2010 exhaust emission standards and 2010-later evaporative emission standards set by the U.S. Environmental Protection Agency.



AMERICAN SUZUKI MOTOR CORPORATION
P.O. BOX 1100 BREA, CA 92822-1100
<http://www.suzukimarine.com>